

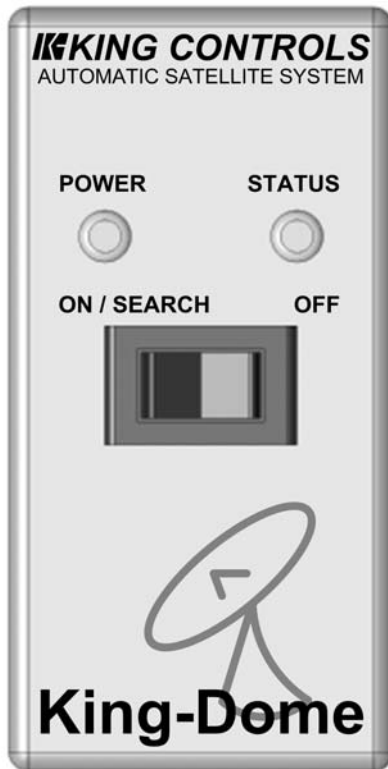

Automatic Satellite System #9702

Installation and Operating Instructions



Satellite Solutions for Mobile Markets

5100 W. 36th Street, St. Louis Park, MN 55416
Phone: 800-982-9920 Fax: 952-922-8424

www.kingcontrols.com

IMPORTANT!

The satellite TV market is expanding and changing. The information in this manual was accurate at the time of printing. If your King-Dome does not operate as outlined in this manual please call King Controls at 1-800-982-9920 or visit our website at www.kingcontrols.com.

TABLE OF CONTENTS

Section	Contents	Page
1.	INTRODUCTION.....	2
2.	DEFINITION OF TERMS	3
3.	INSTALLATION	4-11
4.	OPERATION	12
5.	MULTI-SWITCH	13
6.	TROUBLESHOOTING	14
7.	MAINTENANCE	15
8.	LIMITED WARRANTY	16

DIRECTV® is an official trademark of DIRECTV, division of GM Hughes Electronics Corporation.

Dish Network® is an official trademark of Echostar Communications Corporation.

Bell ExpressVu® is an official trademark of Bell Canada.

DVB® is a trademark of the DVB Digital Video Broadcast Project (1991-1996)

The King-Dome Automatic Satellite System includes 2 main components. **(Fig. 1)**

Dome (Antenna) Unit	Located on the roof of the vehicle. The dish is covered by a protective dome that keeps operational components free from the elements.
Controller	Located in the vehicle. Activates the search mode and provides limited diagnostic functions using the status light.

Note: A TV, satellite receiver, and program subscription are also required for satellite TV viewing. (Not supplied by King Controls.)

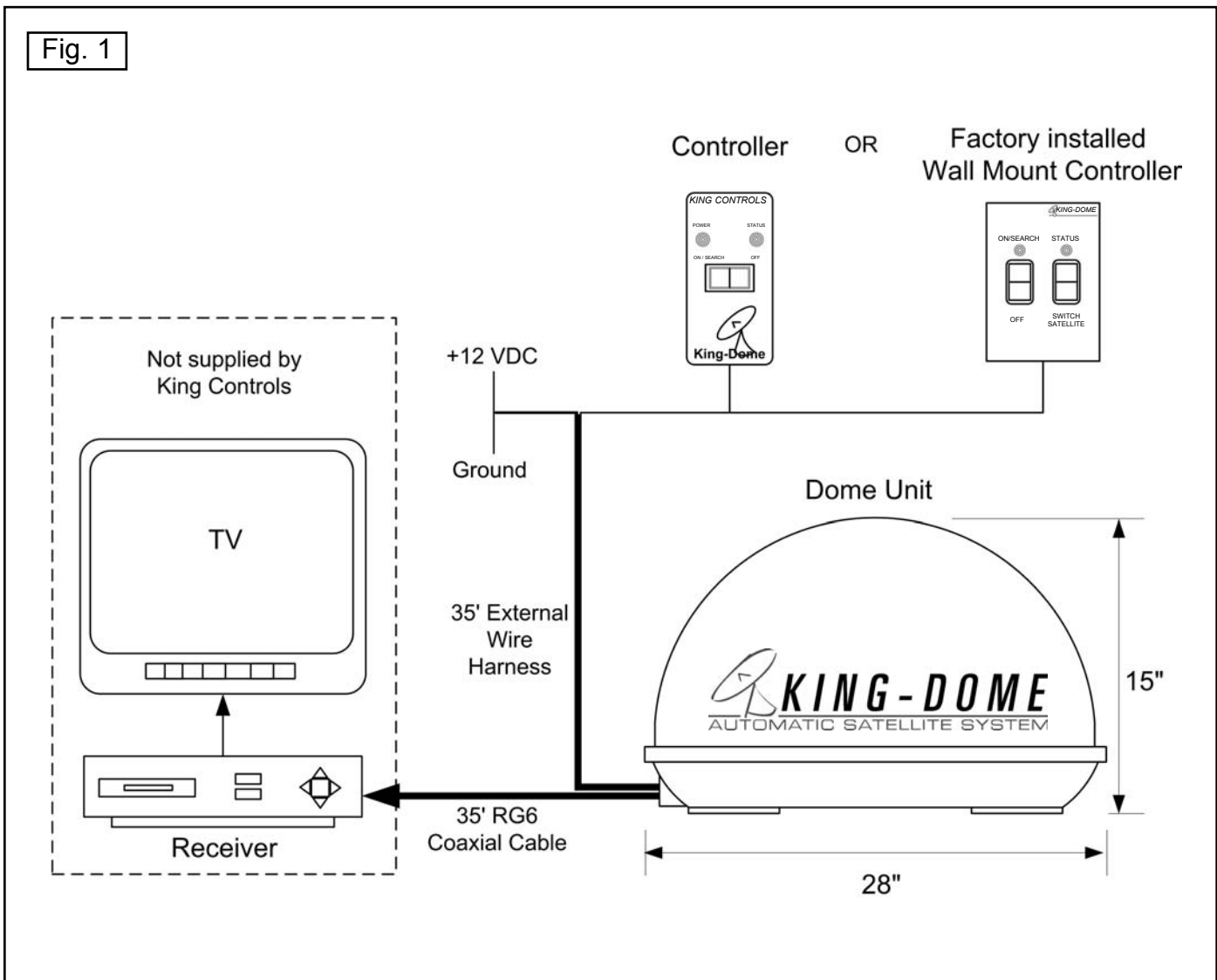

AZIMUTH: Circular rotation around the vehicle.
 (like a clock face: front of vehicle is 12:00, rear is 6:00) (Fig. 2)

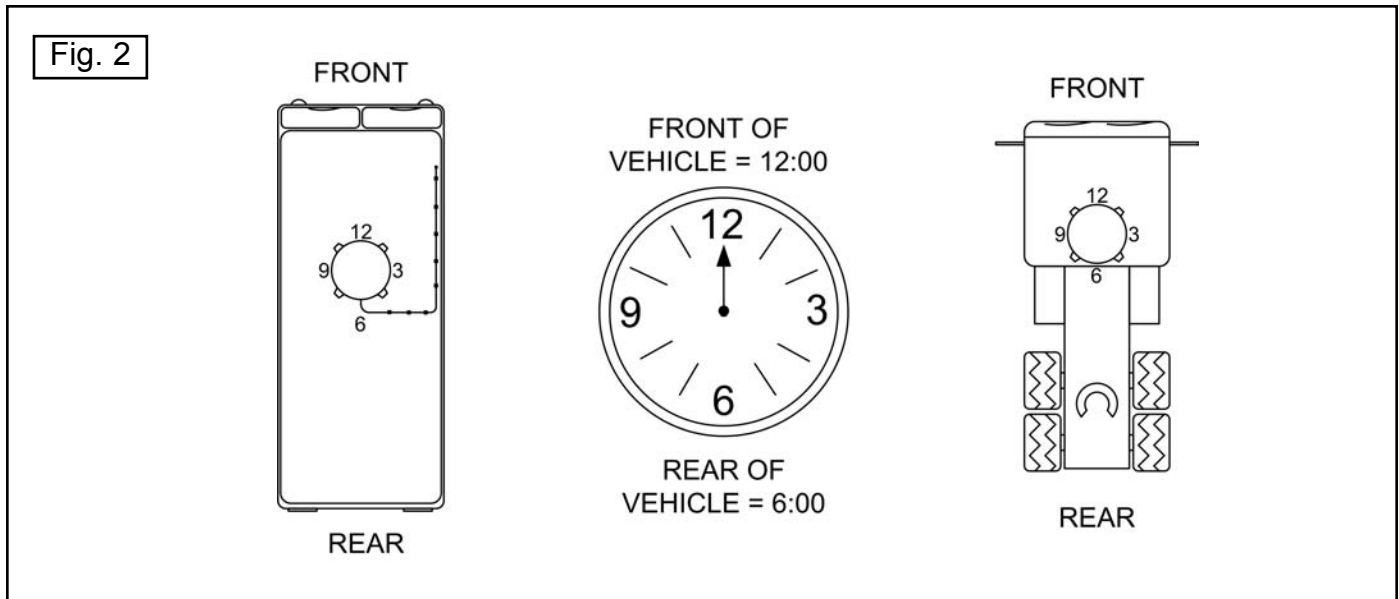

ELEVATION: Angle in degrees measured from the ground plane. (Fig. 3)

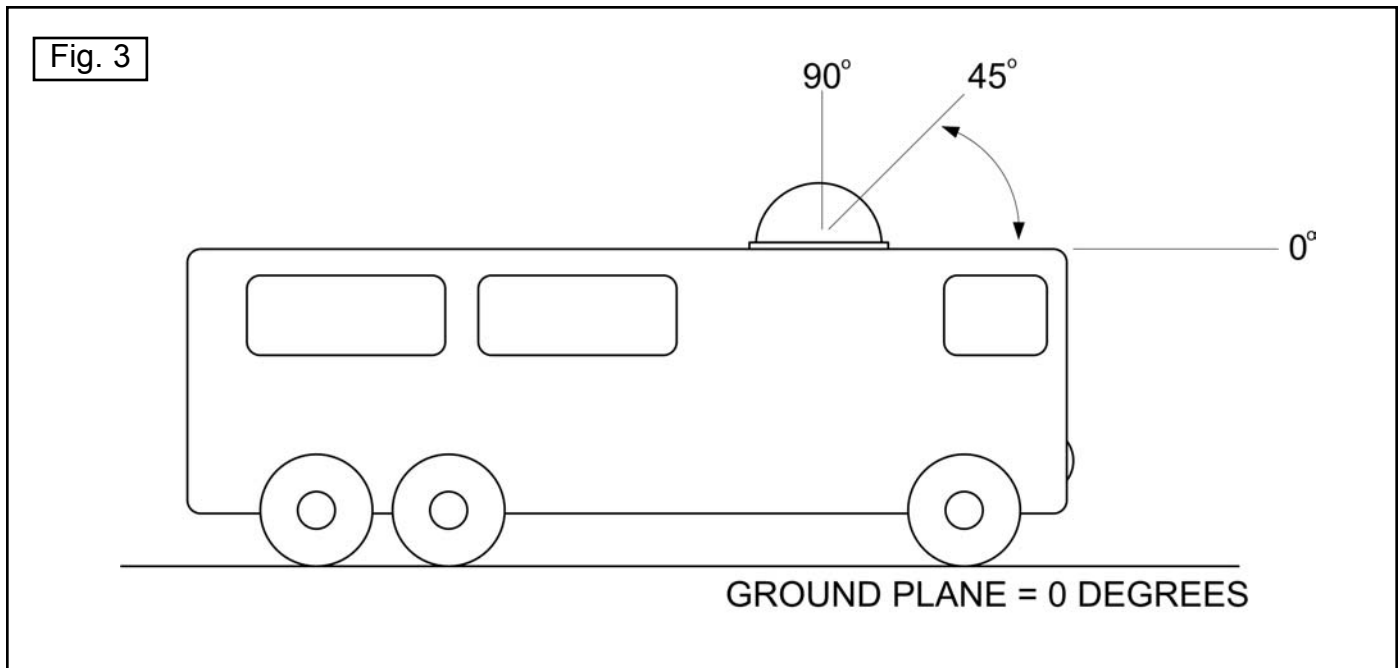

SIGNAL STRENGTH: Intensity of electronic signal received from the satellite transmission.

TOOLS AND MATERIALS REQUIRED:

- drill and drill bit set
- tape measure
- 7/16" open end wrench (coax connections)
- adhesive sealant (compatible with roof material)
- appropriate fasteners to install all components and wiring
- 5/32" allen wrench, channel lock or pliers (to remove shipping bolt)

KIT CONTENTS:

1. Unpack and identify all components. (Fig. 4)

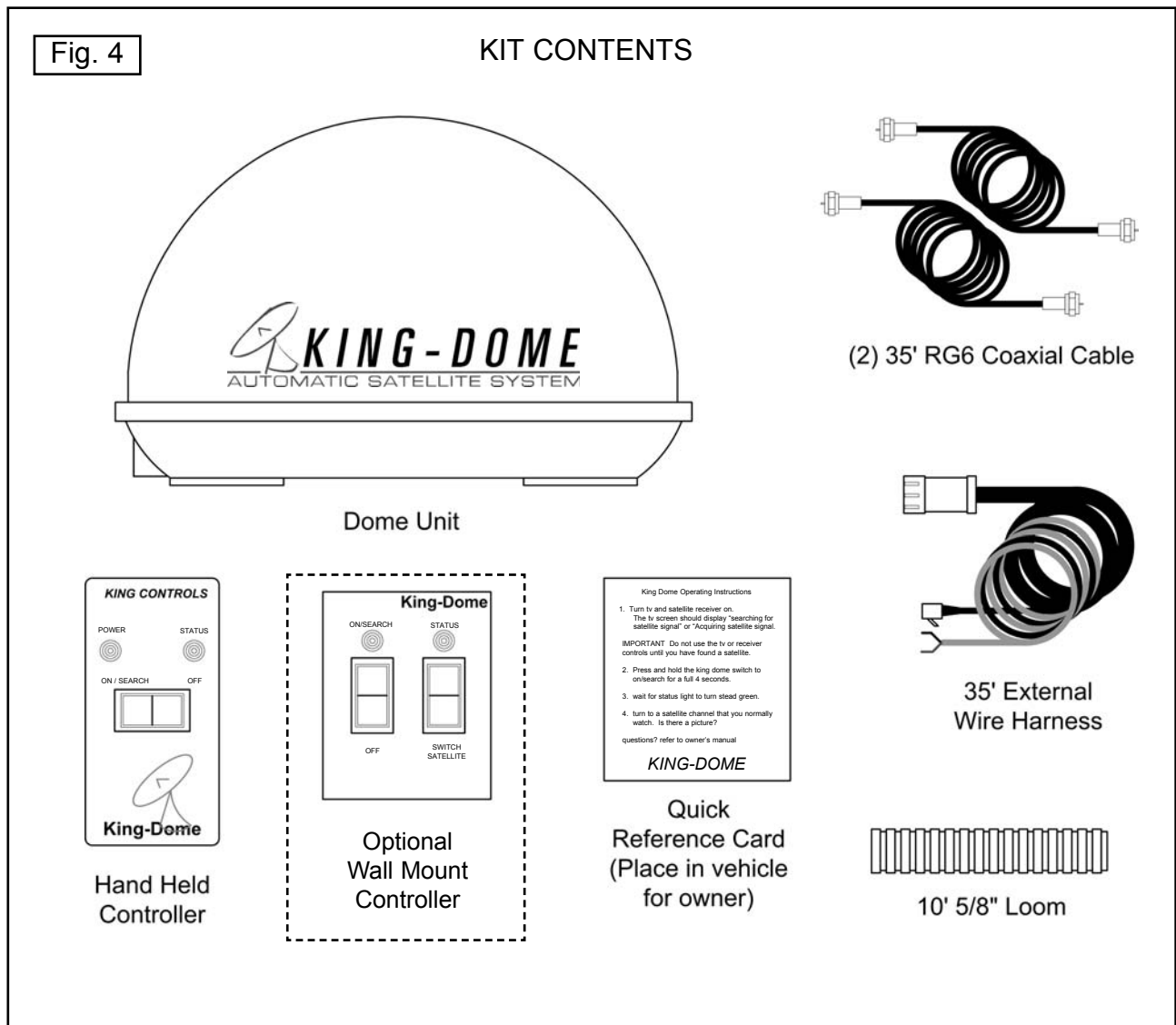

IMPORTANT! The plastic spacer and bolt must be removed from the bottom of the dome unit prior to installation. DO NOT REMOVE THE DOME COVER TO REMOVE THIS SHIPPING RESTRAINT.

2. Remove and discard the plastic spacer and bolt that pass through the bottom of the base. (Fig. 5)

Fig. 5

DO NOT REMOVE DOME COVER

Do not remove Blue Protective Sheet or Red Sticker until installation is complete.

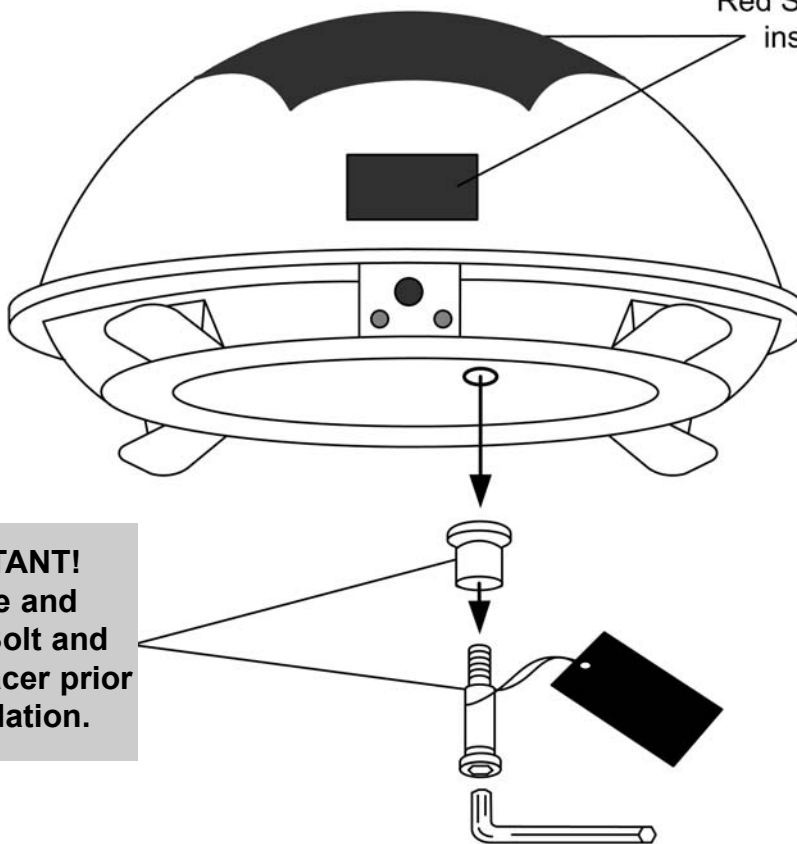

IMPORTANT!
Remove and discard Bolt and Plastic Spacer prior to installation.

5/32" Allen Wrench, Channel Lock or Pliers

DOME LOCATION

3. Select an area on the roof for the dome unit and the location where the wiring will enter the vehicle through the roof to the satellite receiver, controller, and 12 volt power source inside, using the following criteria:
 - a) The shortest distance between the dome unit and the satellite receiver is most desirable.
 - b) The dome unit requires a 28 inch diameter mounting area.
 - c) The dome unit should be mounted on the centerline of the vehicle. Mounting off centerline reduces electronic level compensation.
 - d) There must be no "line of sight" obstructions. Air conditioning units, other antennas, and storage areas that are too close to the dome unit may prevent the satellite signal from reaching the dish. **(Fig. 6)**

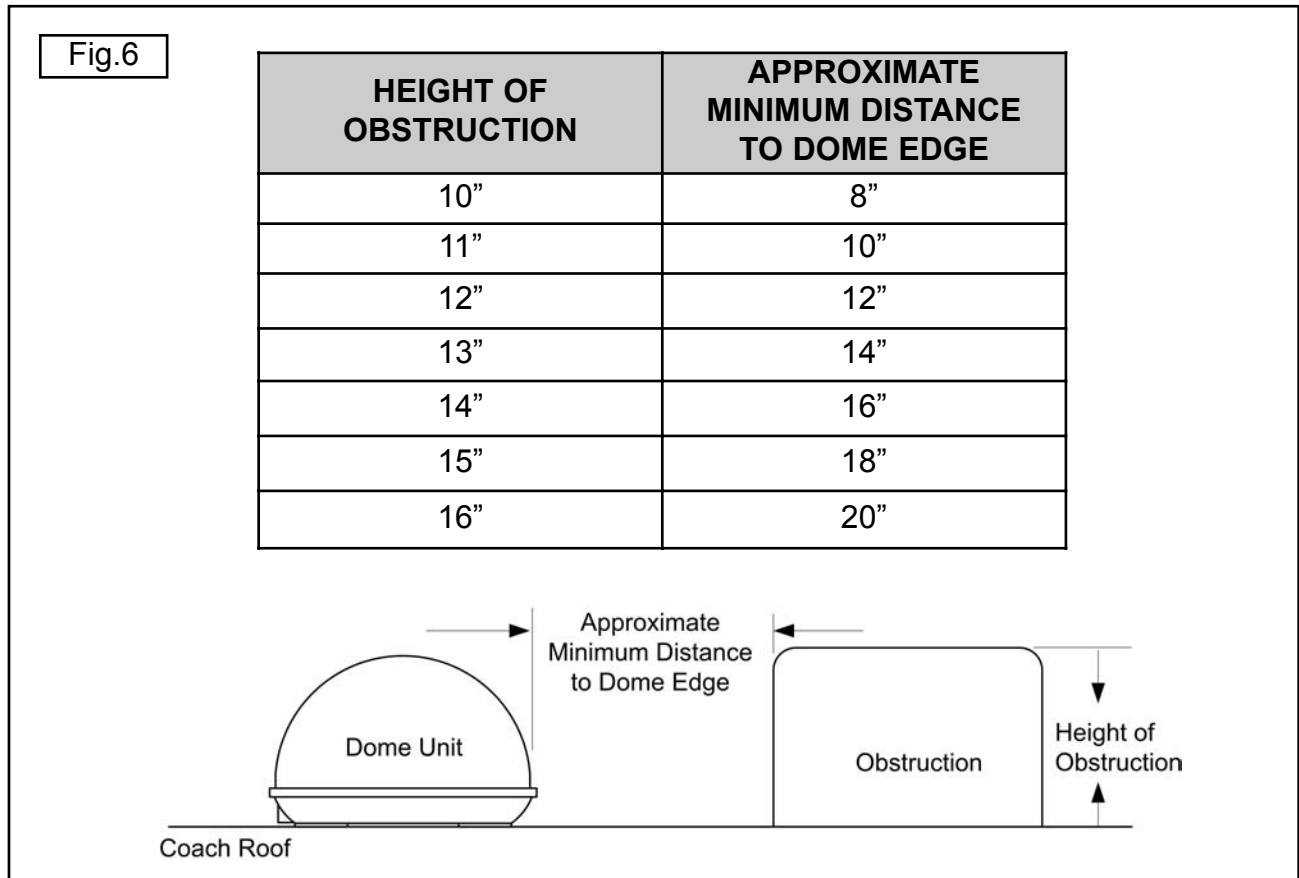

IMPORTANT! For installations on trucks with air shields, a bracket must be used for mounting the dome unit. The dome unit **MUST** be mounted to the air ride cab: **NEVER** to any structure mounted directly to the frame.

See bracket instructions for proper installation. (Fig. 7)

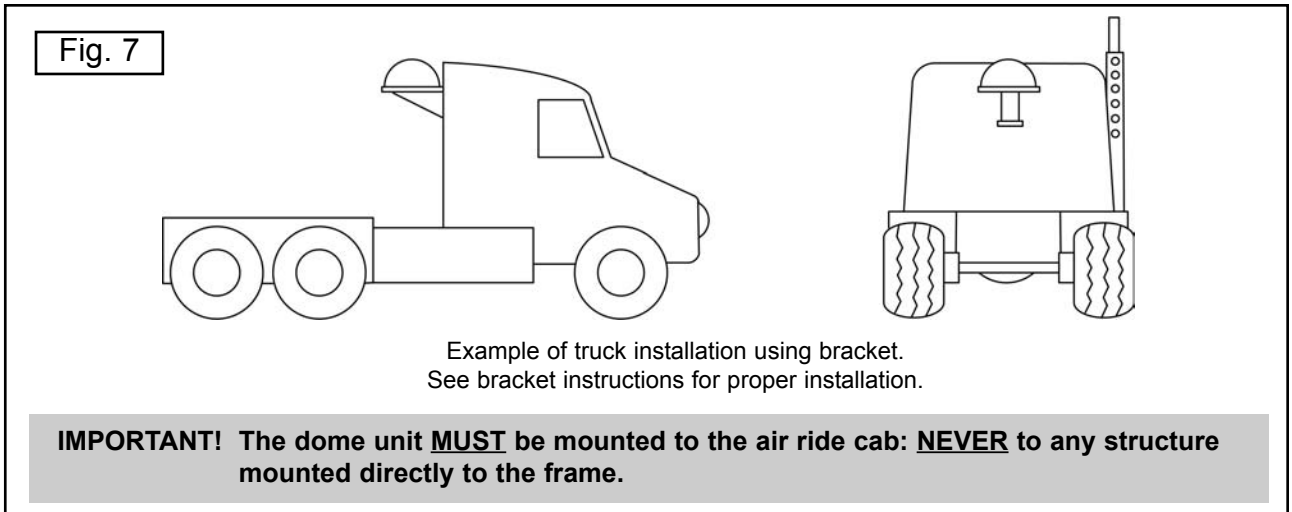

DOMES INSTALLATION

IMPORTANT! Make sure shipping restraint is removed from bottom of dome unit. (Fig. 5, Page 5)

Cable connections must ALWAYS be positioned facing the rear of vehicle.

4. Place dome unit on installation location chosen using the criteria discussed in the previous section. Shipping restraint must be removed (**Fig. 5, Page 5**), and cable connections must be positioned facing rear of vehicle.
5. The dome unit must be positioned so that both feet on each side of the vehicle are equal distances from the roof edge. This should be checked by measuring the distance from each feet to the roof edge. Confirm that these measurements are equal. (**Fig. 8**)

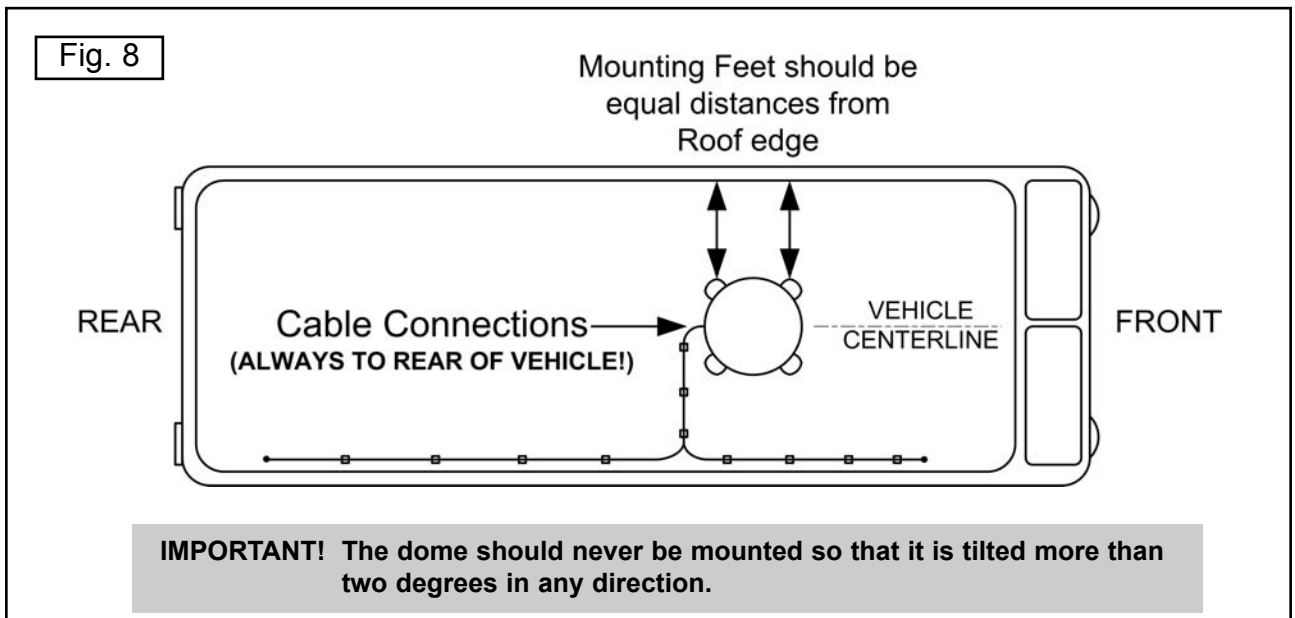

Note: The installer is responsible for determining the most appropriate fastener to secure the dome to the roof. Depending on the roof material, fasteners such as lag screws, well nuts, sheet metal screws, toggle bolts and T anchors may be used, and should always be used in combination with a roof compatible sealant.

The installer is responsible for weatherproofing all holes with sealant.

6. Mount the dome unit. Use the pre-drilled holes in the mounting feet as a guide to install the fasteners into the roof. Use additional fasteners whenever necessary.
7. Test that the dome unit is secure by pulling upward from each foot location.

EXTERNAL WIRING

8. Plug external wire harness into wiring port on back of dome unit and tighten connection until it clicks past the detent lock. **(Fig. 9)**

Note: The King-Dome is wired for a dual LNB. There are two coaxial ports on the back of the dome unit. The one labeled "MAIN" **MUST** be connected to the main receiver in vehicle. The one labeled "AUX" can be used for an additional receiver.

9. Connect 35' coax cable to coax port labeled MAIN on back of dome unit and tighten connection. If using a second receiver, connect second 35' coax cable to coax port labeled AUX and tighten connection. Do not over tighten coax connections. **(Fig. 9)**

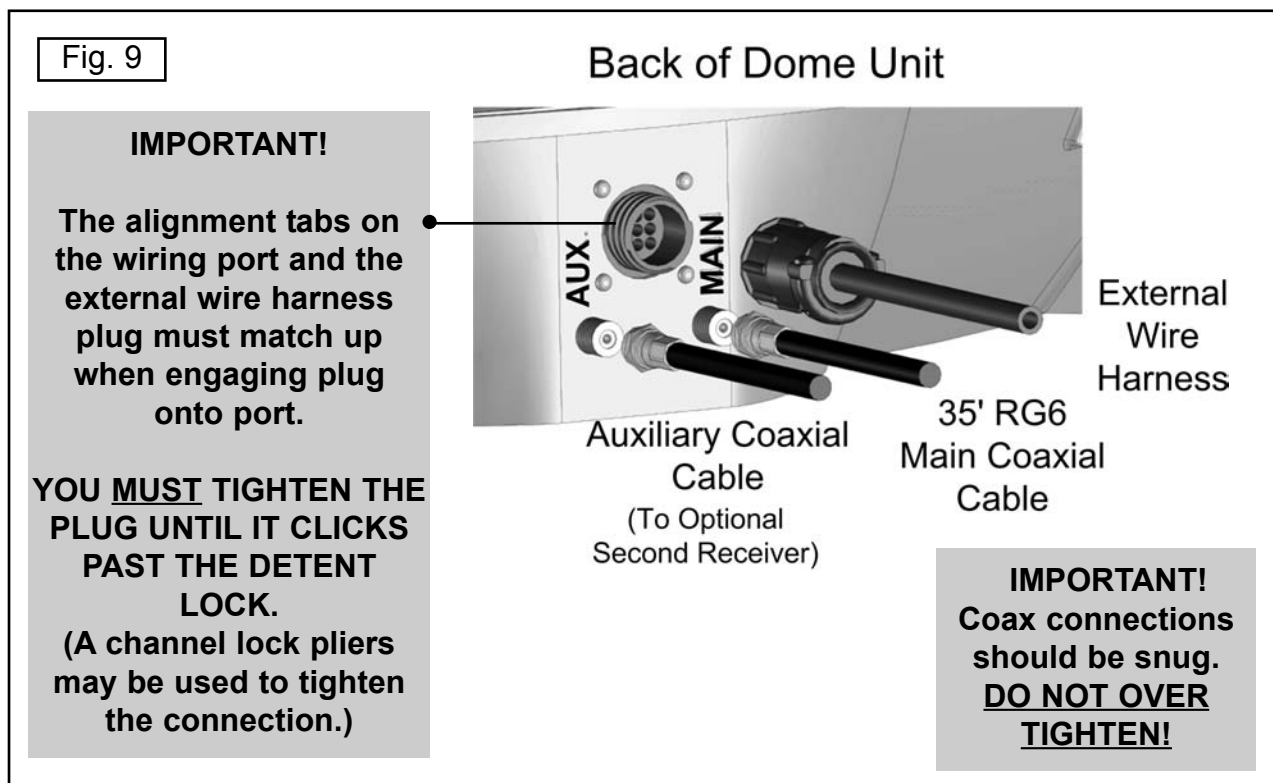

AVOID SHARP BENDS WHEN ROUTING COAX!



NOT CORRECT



CORRECT

10. Run wires from the back of the dome unit to the roof edge, then along edge to location where wiring will be fed into the vehicle. (If installing an optional second receiver, run auxiliary coax to location where it will enter the vehicle.) Secure wiring to roof every 12-18 inches. (**Fig. 10**)
11. Drill 5/8" hole through the roof and into the cabinet where receiver is stored. Feed wiring down through hole. Seal opening with roof compatible sealant so that it is entirely waterproof (inside and outside of the 5/8" hole). Repeat for optional second receiver. (**Fig. 10**)

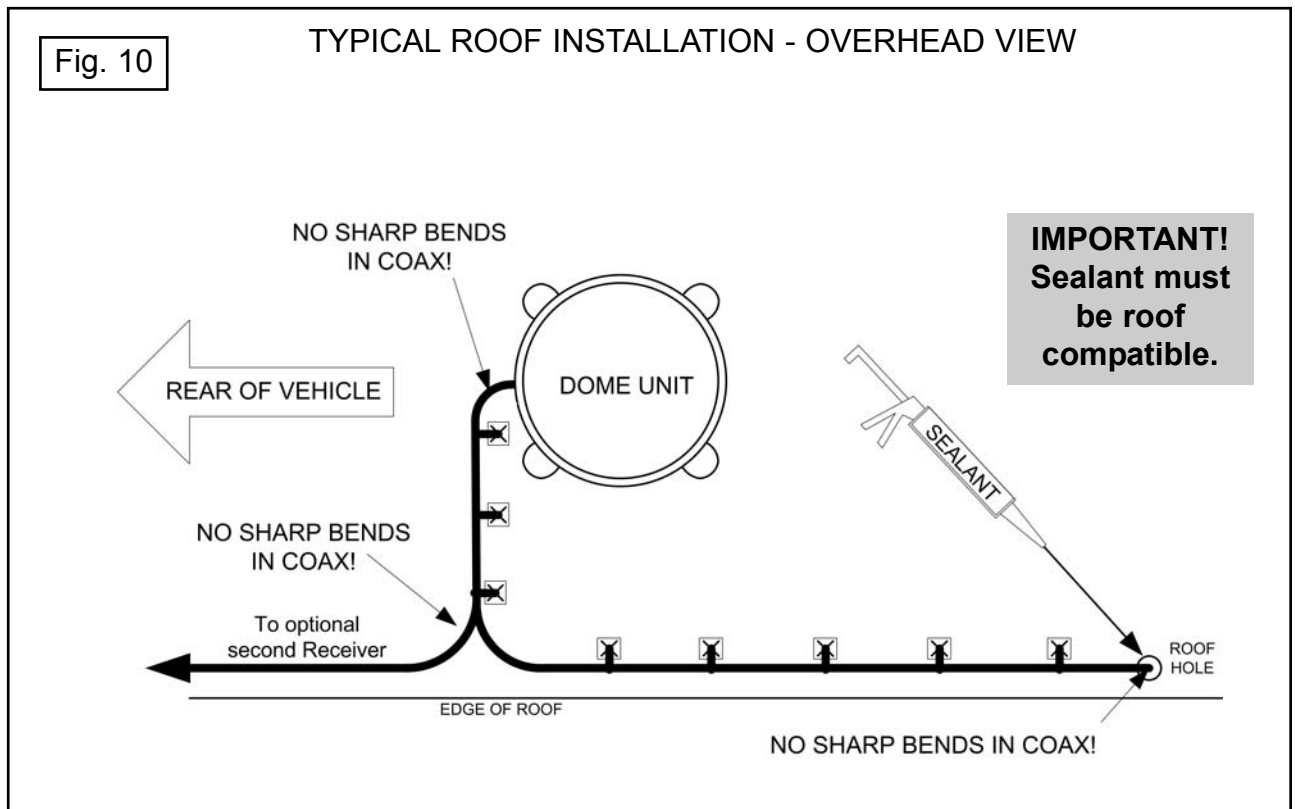

12. Remove blue protective sheet and red "position to rear" sticker from the dome unit.

AVOID SHARP BENDS WHEN ROUTING COAX!



NOT CORRECT



CORRECT

INTERNAL WIRING

IMPORTANT: The connection between the dome unit and the receiver must be a direct connection with no devices in between. Any other devices should be downstream from the receiver.

13. Inside vehicle, connect main coax from the dome unit directly to the “satellite in” port of the main receiver. Do not go through an “A-B” or any other switch, box, or booster. Connect auxiliary coax directly to optional second receiver.

IMPORTANT: Power connection must be a non-shared circuit. Excessive current draw on the circuit will cause the unit to operate improperly. Power and ground connections must be made after the wires are connected to the dome unit.

14. Connect red and black two conductor wire to a power source and ground. Red connects to +12 volts, and black connects to ground.
15. Plug phone style controller cable into Controller.

ELEVATION PROGRAMMING - OPTIONAL

Note: This unit is factory programmed for DIRECTV elevation 37.8 degrees. To reduce initial satellite acquisition time, program the unit as follows: (Programming is optional. If programming is not performed, the system will automatically adjust its elevation after satellite acquisition.)

16. Find your location on the Elevation Maps below. The elevation line nearest to your location is the elevation you will program.

Example: for Miami, Florida (DIRECTV elevation 52°): use 47° elevation line
 for Miami, Florida (Dish Network elevation 38°): use 37° elevation line

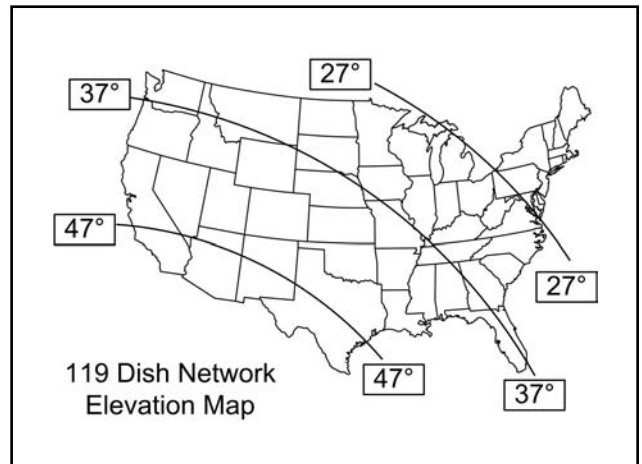
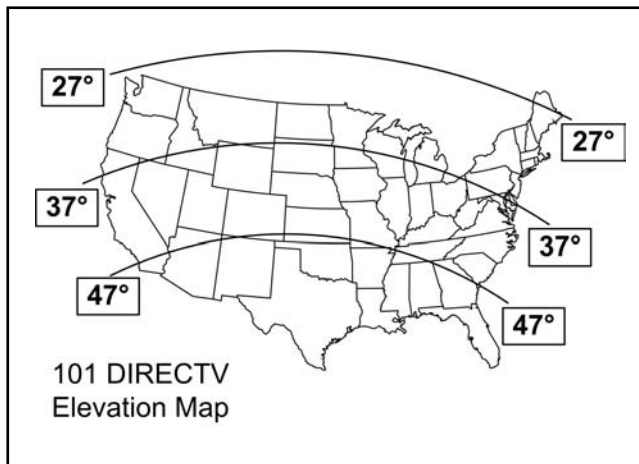

17. Use the Controller to preform the following commands:

<u>SWITCH ACTION</u>	<u>STATUS LIGHT</u>
Momentarily press ON/SEARCH and release.	Turns orange for 1 second, then flashes red and/or green.
Momentarily press ON/SEARCH and release a total of :	
8 times: programs in 27 degree elevation	rapidly flashes red and green
12 times: programs in 37 degree elevation	rapidly flashes red and green
16 times: programs in 47 degree elevation	rapidly flashes red and green
Press ON/SEARCH and HOLD for 3 seconds.	Turns momentarily orange, then back to red or green
Press OFF.	OFF.

IMPORTANT! There must be a clear “line of sight” to the southern sky. Mountains, buildings, trees, telephone poles, etc. can all block the satellite signal from reaching the dish.

The distance driven since last performing a search may affect how long it takes for the King Dome to find the satellite.

Satellite TV and receiver technology are constantly changing. If you experience difficulty go to www.kingcontrols.com or contact the King Controls Service Department at 1-800-982-9920.

1. Turn on TV and Receiver. “Searching for Satellite” or similar will appear on TV screen.

2. On King Dome controller, press and hold ON/SEARCH for **4 SECONDS**. Power light turns steady GREEN.

Hand Held Controller

Wall Mount Controller

STATUS LIGHT

- a) flashes a variety of colors for about one minute
- b) blinks RED
- c) blinks GREEN (may start blinking RED again)
- d) turns steady Green

SYSTEM STATUS

- unit performs self-diagnostic
- search in progress
- potential satellite found
- satellite found



3. Can you view your desired programming?

Note: Receiver may require 2 minutes to download program information.

YES: Turn King-Dome off and enjoy.

IMPORTANT! Do not turn off the controller until you have found your desired satellite and programming.

NO: Press the ON/SEARCH button for one second to continue search. Repeat step until you are locked onto the correct satellite.



FOR DISH 500 SUBSCRIBERS

After you have locked onto the 110 or 119 satellite using the operation procedure in Section 4, you can use the Wall Mount Multi-Switch Controller to move back and forth between the 110 and 119 satellites.

1. a) If you are locked onto the 110 satellite, press the multi-switch UP for one second. The antenna will automatically move to the 119 satellite.



- b) Press the multi-switch DOWN for one second to automatically return to the 110 satellite.

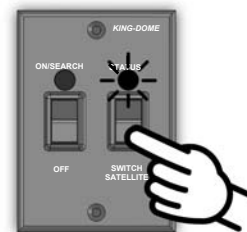

2. a) If you are locked onto the 119 satellite, press the multi-switch DOWN for one second. The antenna will automatically move to the 110 satellite.



- b) Press the multi-switch UP for one second to automatically return to the 119 satellite.

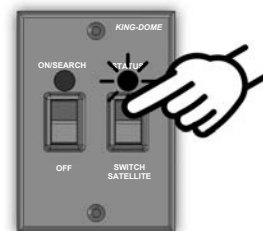

SYMPTOM	POSSIBLE REASON	COARSE OF ACTION
Unit does not find satellite. (STATUS light blinks red and/or green.)	Did not hold ON/SEARCH button for a full 4 SECONDS.	Hold ON/SEARCH button for a full 4 seconds.
STATUS light blinks orange.	Before search: bad coax connection After unsuccessful search (approximately 25 minutes): obstruction in line of sight between dome and satellite	Call King Controls Move vehicle to have unobstructed view of southern sky
STATUS light does not stop rapidly blinking red and green	Self check failed: potential motor problem	Call King Controls
STATUS light does not turn on or is dim	Bad power source (low voltage) Bad power or controller cable connection at dome Bad controller cable connection at controller	Call King Controls



Diagnostic Keypad (Optional)

The Keypad is not included with this unit. It allows the installer to use advanced diagnostics for installation and troubleshooting. To order a Keypad contact your local distributor or call King Controls at 1-800-982-9920.

The King-Dome Satellite System has been designed to be maintenance and trouble free.

For optimum signal strength, keep the dome clean from dirt, bugs, and other debris. Periodic washing of the dome with mild soap and water is recommended.

If you plan on storing your vehicle for long periods of time, it is recommended that the system be put through a search procedure on a quarterly basis to keep all moving parts in good working order.

If you have any comments or questions, please contact the King Controls Service Department at 1-800-982-9920, or email King Controls at info@kingcontrols.com

Every King Controls Satellite System is thoroughly inspected and tested before leaving the factory. It is covered by a two year parts and one year labor limited warranty from the date of original purchase. This warranty does not cover installation and external wiring or refurbished units.

Should any trouble develop during the warranty period, contact King Controls or one of its certified dealers. Only King Controls and certified dealers are authorized to perform warranty evaluations and repairs.

If it is determined that the unit needs to be returned, return COMPLETE product, freight prepaid, to :
King Controls, 5100 West 36th Street, St. Louis Park, MN 55416. If inspection shows the trouble is caused by defective workmanship or material, King Controls will repair (or at its option, replace) without charge.

This warranty does not apply where:

- The product has been abused, misused, improperly installed or improperly maintained.
- Repairs have been made or attempted by others that are not certified by King Controls to do such repairs.
- Repairs are required because of normal wear and tear.
- Alterations have been made to the product.

In no event shall King Controls be liable for any indirect, incidental, or consequential damages from the sale or use of the product. This disclaimer applies both during and after the term of the warranty.

King Controls disclaims liability for any implied warranties, including implied warranties of "merchantability" and "fitness for a specific purpose," after the one year term of this warranty.

This warranty gives you specific legal rights, and you may also have other rights, which vary from state to state. Some states do not allow the exclusion or limitation of incidental or consequential damages, so the above limitation or exclusion may not apply to you. Some states do not allow limitations on how long an implied warranty lasts, so the above limitation may not apply to you.



5100 W. 36th Street, St. Louis Park, MN 55416
Phone: 800-982-9920 Fax: 952-922-8424

www.kingcontrols.com